

21. Suspension

A: INSPECTION

1. FRONT SUSPENSION BALL JOINT

- 1) Lift up the vehicle until front wheels are off ground.
- 2) Grasp the bottom of tire and move it in and out in axial direction. If movement (B) is observed between the brake disc cover (A) and end of front arm (D), ball joint (C) may be excessively worn.

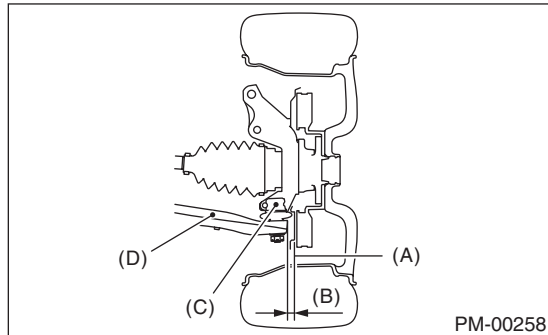

- 3) Next, grasp the end of front arm (C) and move it up and down. If movement (A) between the housing (D) and front arm (C) boss is observed, ball joint (B) may be excessively worn.

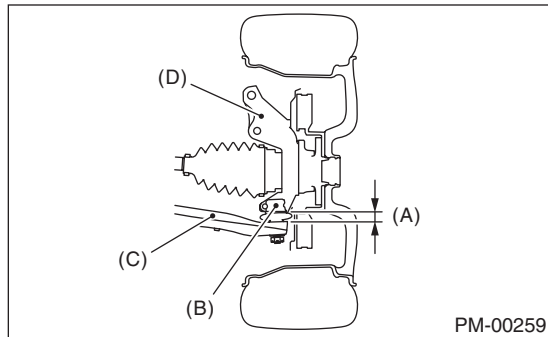

- 4) If the relative movement is observed in the preceding two steps, remove and inspect the ball joint. If the free play exceeds standard value, replace the ball joint. <Ref. to FS-33, Front Ball Joint.>

5) Damage of dust boots

Visually inspect the ball joint dust boots. Replace if ball joint is damaged.

2. REAR SUSPENSION BALL JOINT

- 1) Lift up the vehicle until rear wheels are off ground.
- 2) Grasp the bottom of tire and move it in and out in axial direction.
- 3) If movement is observed between the brake disc cover (A) and end of front lateral link (B), ball joint may be excessively worn.

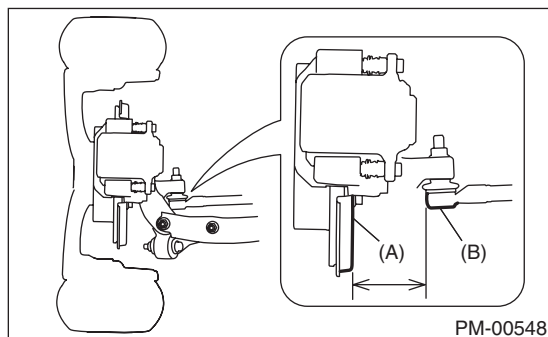

Suspension

PERIODIC MAINTENANCE SERVICES

4) Grasp the end of front lateral link (B) and move it up and down. If movement is observed between the housing (C) and front lateral link (B) boss, ball joint may be excessively worn.

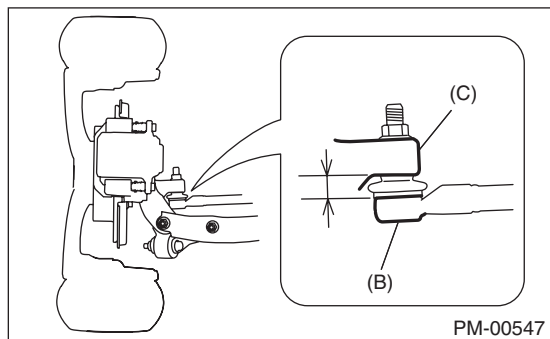

5) If the movement related to the previous two steps is observed, replace the front lateral link. <Ref. to RS-21, Front Lateral Link.>

6) Damage of dust boots

Visually inspect the ball joint dust boots. Replace if front lateral link is damaged.

7) Check the upper arm ball joint (D) and the pillow ball bushing (E) of housing in the same manner.

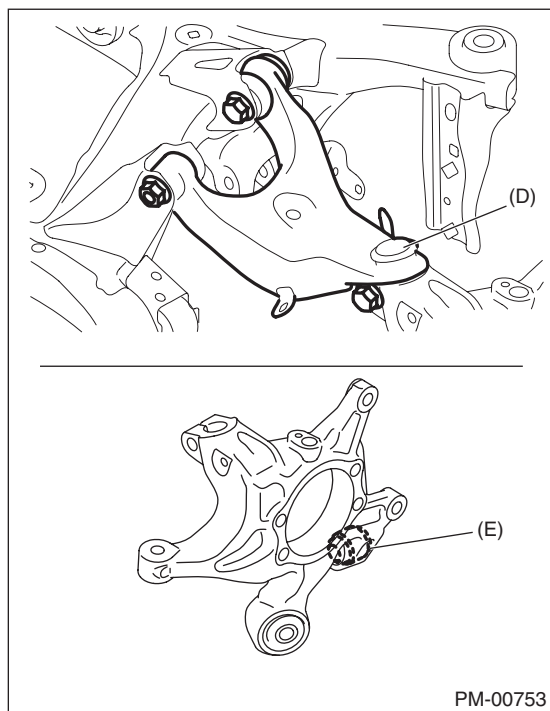

(D) Upper arm ball joint

(E) Pillow ball bushing

3. FRONT, REAR SUSPENSION BUSHING

Apply pressure with tire lever etc, and inspect the bushing for excessive wear or damage. If defective, replace the bushing.

- Front suspension bushing

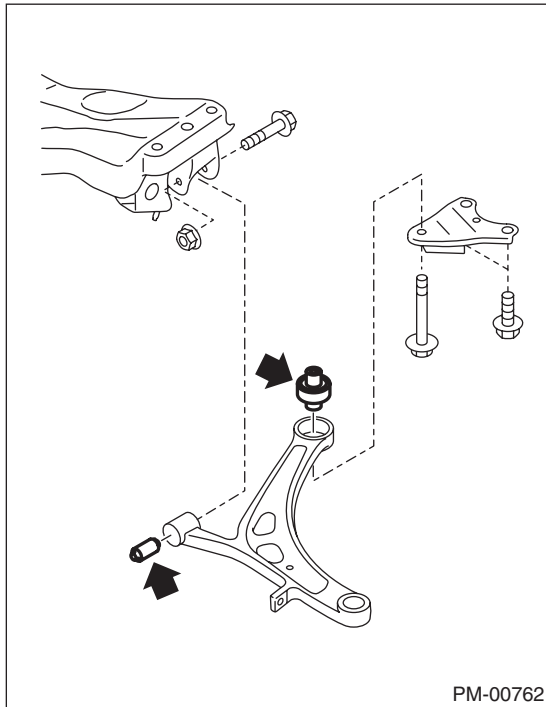

- Rear suspension bushing

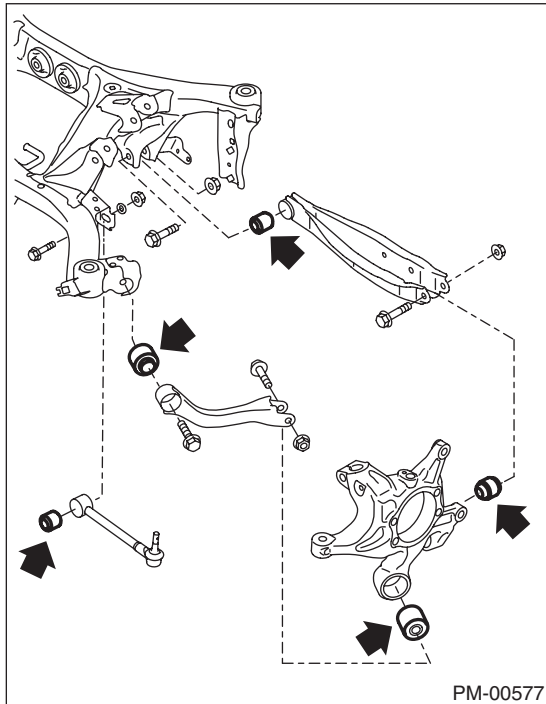

4. WHEEL ARCH HEIGHT

Refer to “FS” section for wheel arch height inspection. <Ref. to FS-11, WHEEL ARCH HEIGHT, INSPECTION, Wheel Alignment.>

Suspension

PERIODIC MAINTENANCE SERVICES

5. WHEEL ALIGNMENT

Measure and adjust the front and rear wheel alignment at a time. Refer to “FS” section for measurement and adjustment of wheel alignment. <Ref. to FS-10, INSPECTION, Wheel Alignment.>

6. OIL LEAKAGE OF STRUT AND SHOCK ABSORBER

Visually inspect the front strut and rear shock absorber for oil leakage. Replace the front strut and rear shock absorber if oil leaks excessively.

7. TIGHTNESS OF BOLTS AND NUTS

Check the bolts and nuts for looseness. Retighten the bolts and nuts to specified torque. If the self-locking nuts and bolts are removed, replace them with new parts. <Ref. to FS-2, General Description.> <Ref. to RS-2, General Description.>

8. DAMAGE TO SUSPENSION PARTS

Check the following parts and the fastening portion of the vehicle body for deformation or excessive rusting which impairs the suspension. Thoroughly remove the deposits of the lower spring seat of strut where dust or mud are likely piled up. If necessary, replace the damaged parts with new parts. If minor rust formation, pitting, etc. are noted, remove the rust and take rust prevention measure.

- Front suspension
 - Front arm
 - Front crossmember
 - Strut
- Rear suspension
 - Sub frame
 - Front lateral link
 - Rear lateral link
 - Upper arm
 - Trailing link
 - Shock absorber
- In the area where salt is sprayed to melt snow on a road in winter, check suspension parts for damage caused by rust every 12 months after lapse of 60 months. Take rust prevention measures as required.